

Ergonomic two-component handle

Steel barrel

Valve head

Precision pressure gauge

Steel base



MAX
10
BAR

MAX
144
PSI



Exchange gauge floor pumps

1. Loosen the union nut on the pressure gauge cap.

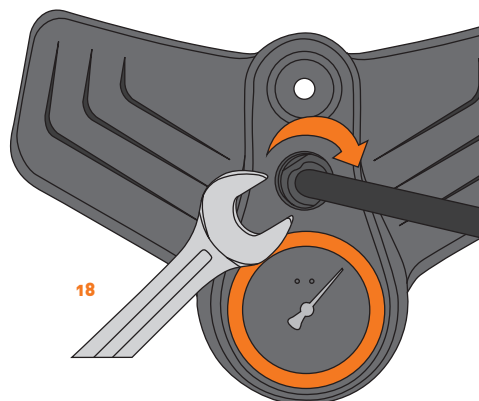

2. Pull up the pressure gauge cap.

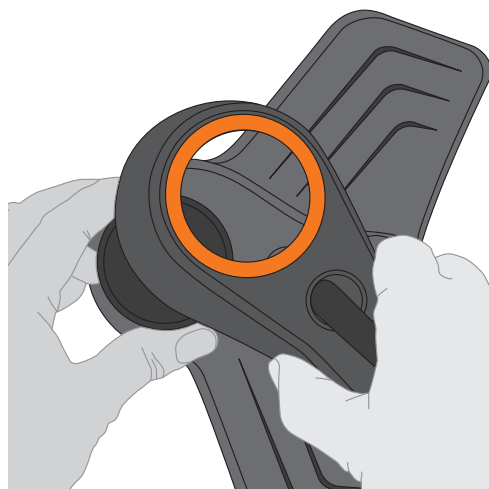

3. Unscrew the pressure gauge at the bottom with an Allen key (size 10).

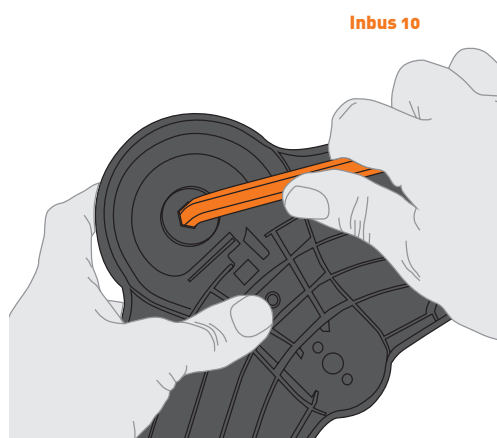

4. Insert a new pressure gauge into the pressure gauge holder.

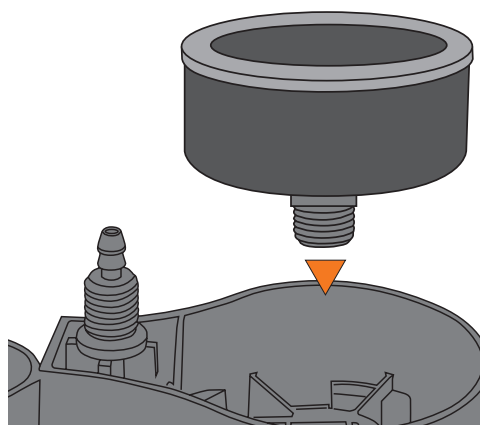

5. Screw on the pressure gauge with a maximum torque of 2 Nm.

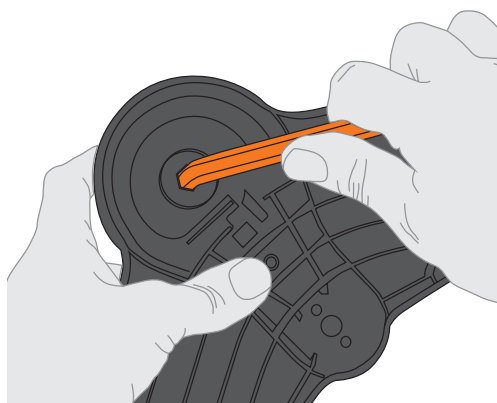

6. Push the pressure gauge cap down again and secure it with the union nut.

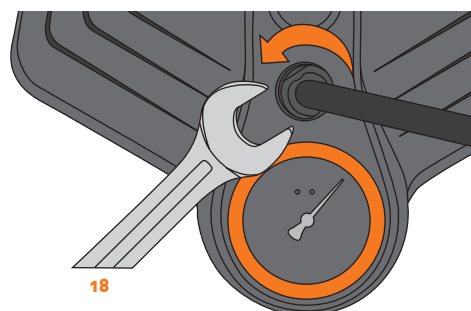

Exchange rubber sealing cuff floor pumps

1. Remove the two Torx screws (T25) of the hose holder. Pull the cylinder rod out of the tube with a strong jerk.

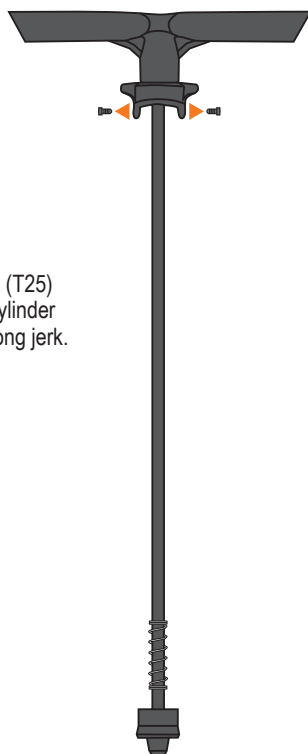

2. Remove the old cup seal. If necessary, use a tool to do this (e.g. screwdriver).

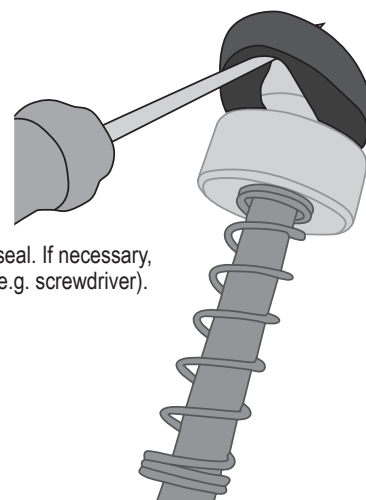

3. Place the new cup over the cylinder rod until it is positioned in the designated joint.

CAUTION: Make sure that it is on the correct side!

4. Grease the rubber cup seal, re-insert the cylinder rod and screw it in.

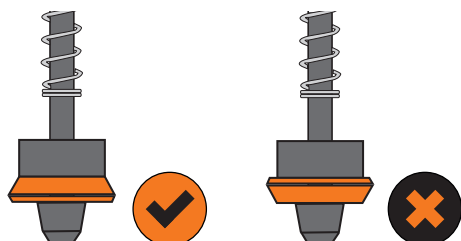

Exchange recovery system

1. Loosen the union nut on the pressure gauge cap.

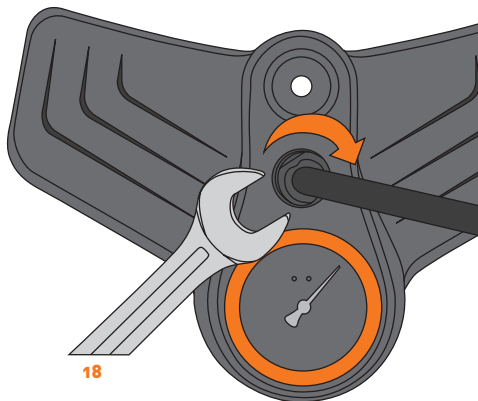

2. Pull up the pressure gauge cap.

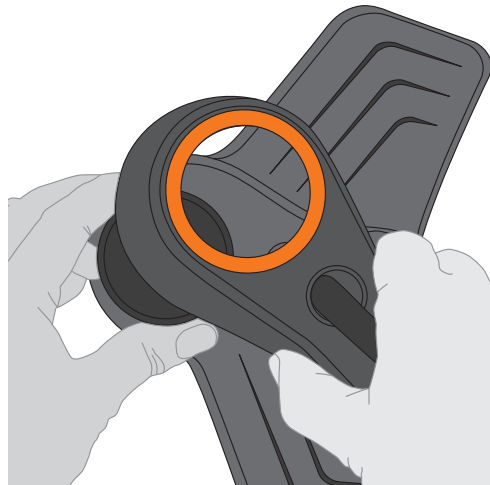

3. Unscrew the pressure gauge at the bottom with an Allen key (size 10).

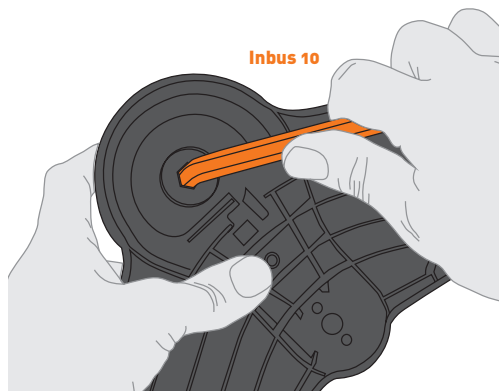

4. Turn the pressure gauge holder approximately 45° anti-clockwise until you feel resistance. Then pull out the pressure gauge holder.

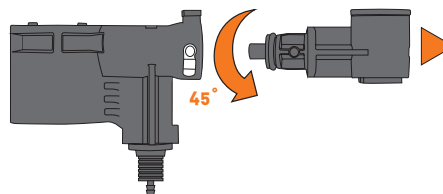

5. Replace the non-return valve system and follow the steps mentioned above in reverse order.

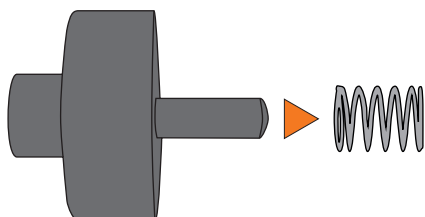

6. **ATTENTION:** Please make sure that the non-return valve system is correctly positioned in the designated fixing. Check that the spring is fitted securely!

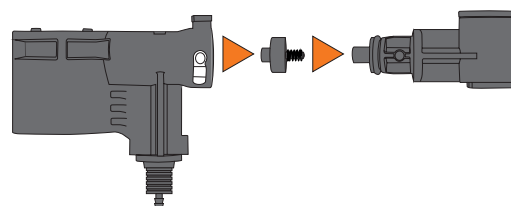

Exchange valve seals

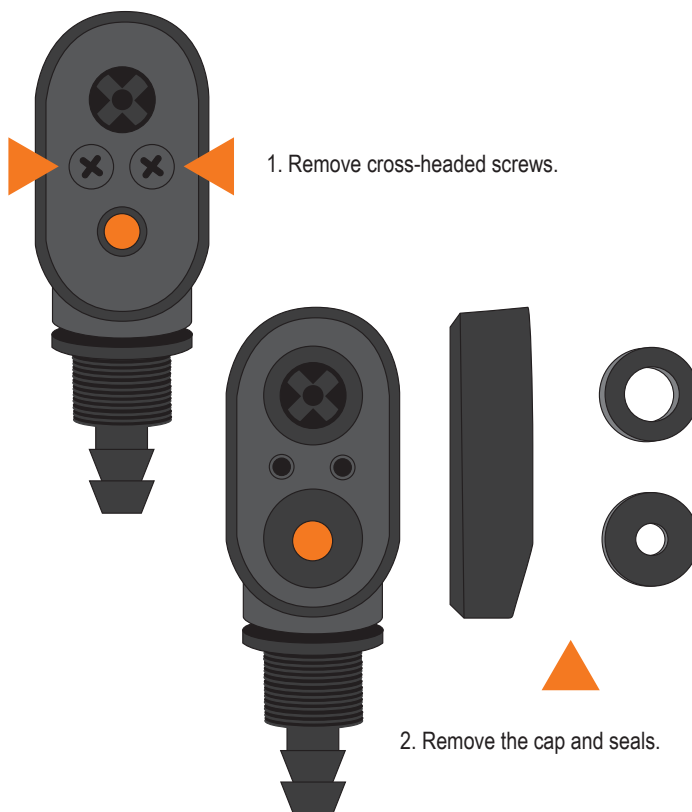

3. Insert new seals.

ATTENTION: Different seals for Schrader and Presta.

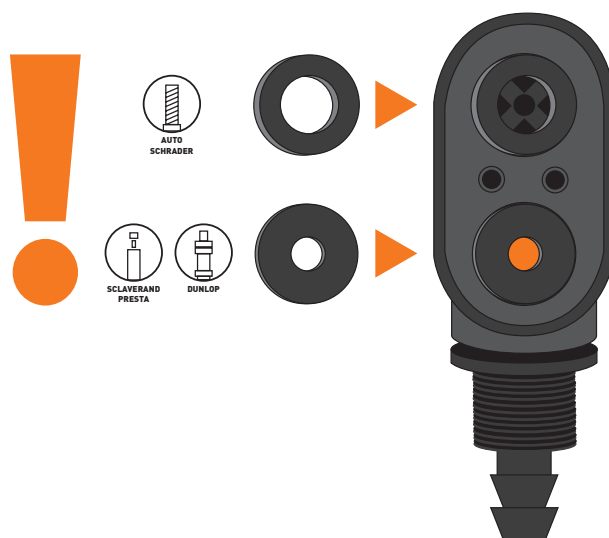

4. Replace the cap and screw it tight.